

PRACTICAL USES OF KINETIC SEPARATION TECHNOLOGY IN SAMPLE CONDITIONING

Glenn Sheffield
2009 19th Ave. N.
Texas City, TX 77590

Carroll Cobb
P.O. Box 9
Colbert, GA 30628

KEYWORDS

Kinetic Energy Separation Technology, Kinetic separator, Polishing Chamber, Sample Conditioning Systems, Fast Loop Chamber, Fluid Boundary Shear Stress, Graduated Porosity Filters, Filters in Series, Parallel Filters, Backflush, Blowback, Kinetic Energy Separators Coolers, Representative Sample.

ABSTRACT

This paper describes Kinetic Energy Separation (KES) and how the concept has been applied and improved as well as a description of some beneficial features of the kinetic separator. The theory of operation is described in detail, justification for its use, and practical applications arise is explained. The effect of temperature, flow, pressure, and expansion in the typical KES application are also covered. The practical aspect of the KES design is further detailed. The standard designs are covered as well as the backflush and cooler applications. The different filter configuration such as varied porosity in series and parallel applications with single porosity is explained. The advantage and design of KES with a cooler is covered.

INTRODUCTION

The kinetics of the control volume are often overlooked in discussions of the relatively limited array of devices that aid in the separation of contaminants from analyzer samples and the principles that govern them. Kinetic separation provides the most versatility with regard to applications, ranges of pressure, rates of flow, and fluid densities that can be accommodated.

While the laws of classic Newtonian physics govern the operation, KES can incorporate filter, boundary shear stress, coalescing, and temperature technology while maintaining an acceptable lag time. The Kinetic separator is easily installed as part of the fast loop, by pass, or single line as both a separator and a filter in both common and special applications. See Figure 1 below.

All the drawings, illustrations, and diagrams shown in this paper represent products and devices protected by existing or pending Patents owned by Sheffield Separator Co., LLC and registered at the USPTO. Pat. 6,444,001.

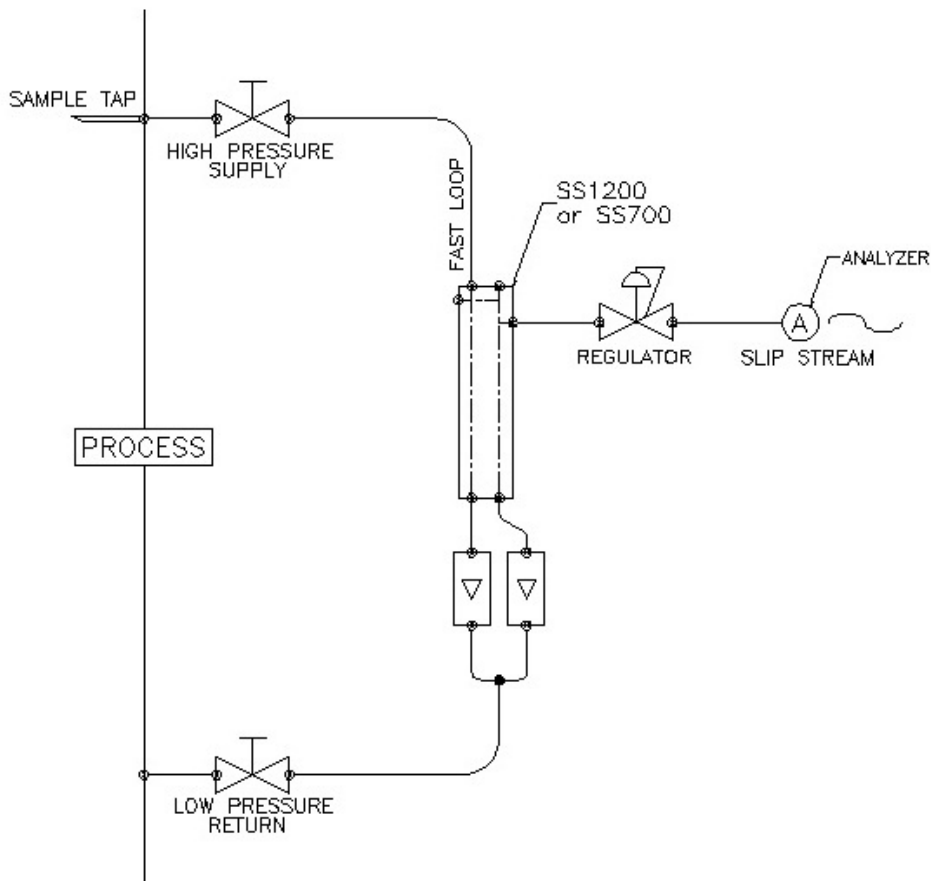

FIGURE 1. FAST LOOP FOR DUAL CHAMBER KINETIC SEPARATOR

KES takes advantage of differing fluid densities to accomplish separation. A more dense contaminant particle in a sample stream will possess a greater inertial energy, rendering it less susceptible to dispersion due to pressure loss. Consequently, it will continue in the flow stream while system pressure and flow path contours force the lighter components to flow toward a low pressure port above the sample outlet.(3)

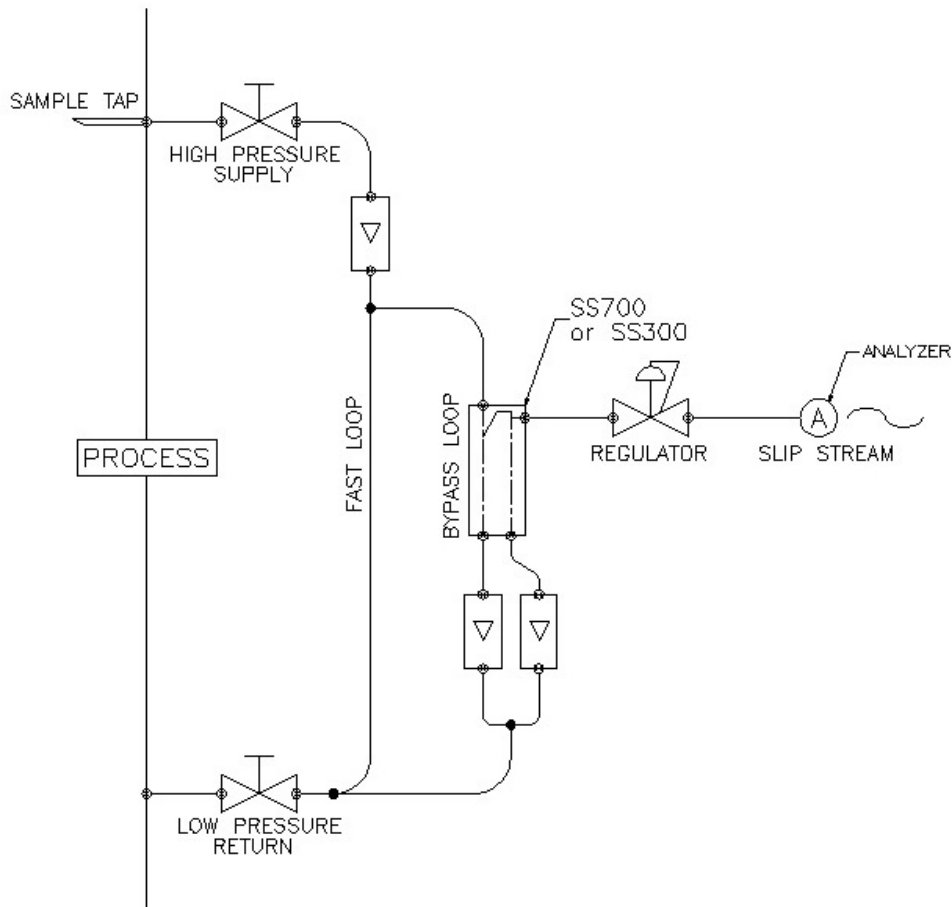

FIGURE 2. BYPASS LOOP FOR DUAL CHAMBER KINETIC SEPARATOR

THEORY OF SEPARATION

In a flowing process stream, the condensate and solid particulates in a gaseous sample, and the heavy immiscible liquids and solid particulates in a liquid sample will tend to remain in the fluid stream, while the lighter representative components will separate from the total contaminated stream and flow toward the lower pressure port. After separation, the kinetic separator returns the remaining sample to the original process stream while the representative sample is sent to a polishing chamber for further purification.

The separator can function at full system pressure, keeping the flow high to optimize inertia, while minimizing lag time. Unlike most conditioning devices, dual chamber kinetic separators have also been found to function satisfactorily in both high and low flow as well as high and low pressure applications.

Filter separators are used because the sample is either experiencing more than one phase and particulate or it is anticipated that such a condition may exist at some time. The latter is usually due to process unit or ambient changes, or unknown sample conditions. This generally occurs when the temperature of the sample is at the dew point of heavier components in the sample. “You should remove any condensate before transporting a gas sample to the analyzer location thereby ensuring that the transport line is dry. After removing the condensate, reduce the sample pressure or heat the line to desaturate the gas.” (3) If increasing the temperature is not feasible the sample must be cooled which results in condensing. By removing the heavier impurities at or below their dew point and then reheating, the sample is in a single phase state at the original temperature. In my experience working with KES, it is very efficient in removing condensables and mist without altering the components of interest or the sample composition in a significant amount. “Obtaining both representative and compatible samples are the primary objectives of the sampling system. (1)

The dual chamber kinetic separator is equipped with internal tubes in both chambers. These tubes provide a “sudden drop of the pressure of a gas. The heat energy needed for expansion has no time to flow into the gas from the surrounding metal so it has to come from the internal energy of the gas itself. The loss of internal energy causes the gas to cool, a phenomenon known as the Joule-Thomson effect.” (2) In cases where the components of interest are significantly lighter than a much heavier contaminant such as water, the cooling effect can be increased by using external coolers. The gas experiencing the sudden pressure drop loses heat and the resulting cooler gas then removes heat from the inner body of the separator. *See Figure 7 Kinetic Cooler*

SEPARATION/PERFORMANCE

Kinetic technology performance can be improved by implementing another largely overlooked principle. It is common knowledge to those skilled in art of knock-out technology that a polished surface will separate contaminants and water more efficiently than a rough surface. This is because water has a high surface tension due to intermolecular cohesive attraction. Polymers such as PTFE Teflon have a very low coefficient of friction. At the high flow rates of the first chamber, the low surface friction of the PTFE Teflon will allow the condensate to traverse the length of the inner wall without defusing to smaller particles, allowing the solid contaminants to move through unobstructed. When the inside chamber of a kinetic separator is lined with PTFE Teflon, the smooth walls improve separation at the high flow rates of the first chamber.

POLISHING CHAMBER

To further improve separation, a second kinetic chamber is used for additional decontamination with minimal additional lag time. The second polishing chamber is actually mandatory for

kinetic separators because “some carryover of fine liquid mist is inevitable”. (3) The flow rate of the first chamber separator will be governed by analyzer requirements. For lag time calculations of the first chamber, only the slipstream flow, which reversed direction, is applicable. This flow is determined by the exit flow of the second chamber. Although the flow rate is substantially lower than the fast loop exiting the first chamber, the optimum flow rate is at least ten times the flow to the analyzer.

An additional advantage to using cylindrical chambers “to be considered is the mixing effect within components (other than pipe or tube) of the sample conditioning system. Where the ratio of height to diameter (both internal) is greater than 10, mixing lag is not a factor.” (2) The lower flow of the second chamber also allows for the utilization of temperature, filtration, and/or coalescing technologies.

Although the flow rate of the second chamber can be as low as $1/10^{\text{th}}$ that of the first chamber, it is sufficient flow to utilize inertia for contaminate removal. In addition, the reduced velocity will allow liquid droplets to separate by gravity as is common with knock-out technology, without the excessive lag time associated with the larger knock-out separators. The separation will be enhanced by the smaller tube in the second chamber. The tube in the first chamber has a 16 to 1 expansion to prevent an excessive pressure drop in the fast loop. The tube in the second chamber is smaller and will have a higher velocity in the tube as well as a 256 to 1 expansion to create greater pressure drop as it exits the tube. The low flow will not affect the cooling but the increased pressure drop will increase the sample cooling. (3)

The length of the protruding tubes is determined by the function of the separator. In a gas sample the greater the length of the tube the greater the travel after the initial 180 degree flow reversal will increase the efficiency of the separation by allowing gravity to overcome light products using the same concept as the long gravity tubes. In applications that can benefit from the process self-cleaning the chamber, it would be beneficial to use a shorter tube. Of course a longer tube may be used in the first chamber to appreciate the benefits of the kinetic separation and a shorter tube in the second polishing chamber to full utilize the self-cleaning aspects to clean the inside of the filter. *See Figure 3*

FILTRATION

A sealed chamber at the top of the second chamber allows the process to flow into a tube in the second chamber via openings in the tubing walls. A long narrow filter housing is created below the seal similar to the cylindrical bypass filter but with a vertical orientation. The port to the analyzer is located just below the sealed chamber. A standard 1/2” hydrophobic depth filter specifically fitted to the entire length of the lower second chamber is used. Because the filter

seats on the bottom of the chamber, the flow moves down the inside of the filter, providing “a scrubbing action to keep the inside of the tube clean. By ensuring that the major flow is over ten times the filtered sample flow, particles are made to impact the filter element at a shallow angle. This, together with the momentum effect of the fast stream, helps to increase the efficacy of the filtration without clogging the element.” (1)

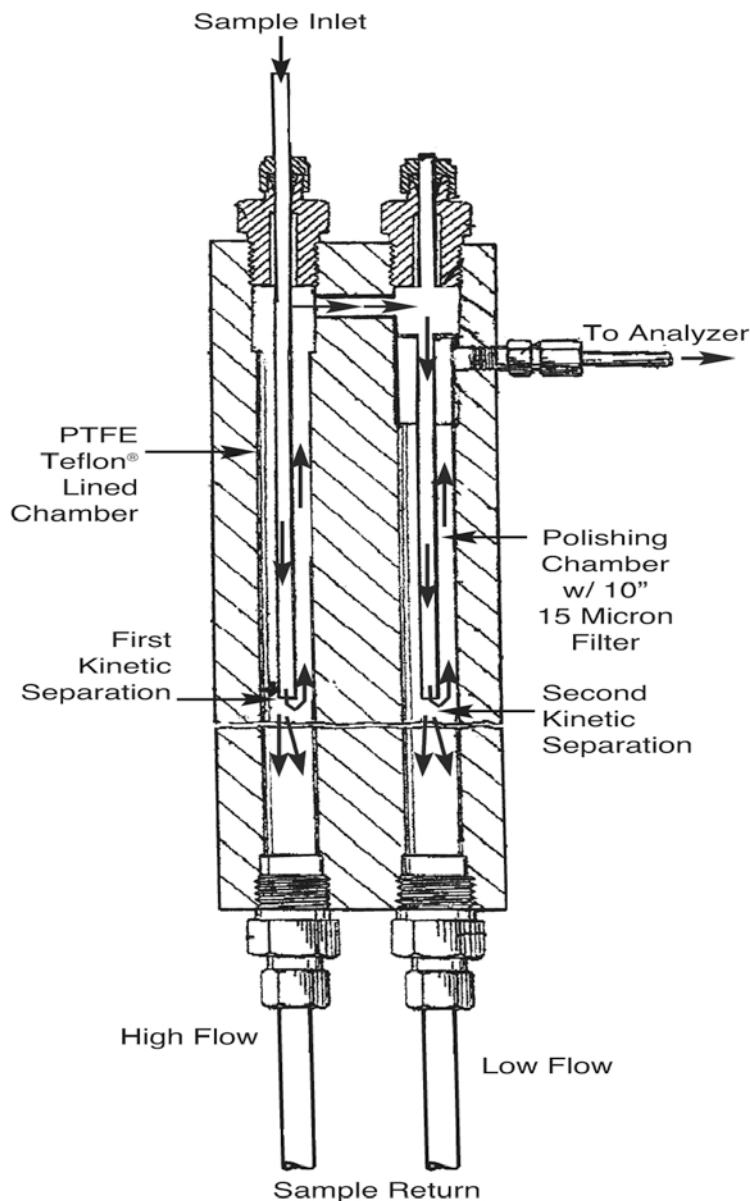

FIGURE 3. LARGE DUAL CHAMBER KINETIC SEPARATOR

GRADUATED POROSITY FILTERS

In the second chamber, the analyzer slipstream must first change direction and then permeate the filter wall as the main flow carries the heavy contaminants down and exits the bottom port to a low pressure return. The principle of a shallow angle is also applicable to the Teflon lined wall of the first chamber. It prevents defusing of large droplets which are easy to separate from the sample into a number of smaller droplets, with less mass and less susceptibility to gravity and inertial effects.

The principles covered above apply to most kinetic energy separators. The illustrations presented are those for the larger separators. Larger separators are desired for applications that are heavily fouled with free water, oil/water mist, and/or particulate. The chambers in these larger separators are at least 10 inches long to take full advantage of the KES. The first chamber is PTFE lined without obstructions and the second is equipped with a full length hydrophobic filter. It should be noted that type and size of separator used is not unique to the analyzer, but rather, is determined by the sample conditions presented by the application. These larger separators are used on the worst case applications such as extreme water or particulate fouling, or with technologies that cannot tolerate even the slightest fouling without risking costly consequences from down time.

When the scope of the application is primarily for filtering the sample, with less maintenance due to filter changes, a filter can be installed in both chambers. The filters will have graduated porosity, in series, allowing for a coarse first pass and a finer polishing second chamber. Besides the longer filter life due to the series design, the kinetic effect will act as a pre-filter removing particulate and liquid impurity before it contacts the walls of the filter. The kinetic separators can be made to function with smaller filters and footprints in less demanding applications in the sample system by merely reducing the length. A medium size separator for less demanding applications and a dual kinetic filter housing as a slip stream filter can be more cost effective for less fouled samples. *See figure 4.*

These less demanding applications use a medium sized Dual Kinetic Filter Separator which is sufficient to handle all but the extreme cases mentioned previously. It can be installed in the Fast Loop as well as the Bypass Loop. The smaller Dual Kinetic Filter Housing is for less fouled applications or as a bypass filter. Even these smaller kinetic separators provide twice the filtration and will last three times as long as a typical single chamber filter housing with the same size filter in the same process. The separator is installed in close proximity to the analyzer to catch condensables that may have occurred due to uneven heating and particulate from larger spent filter or carry over from higher porosity filters. The footprint of these devices can be easily fit into most cabinets. *See figure 5.*

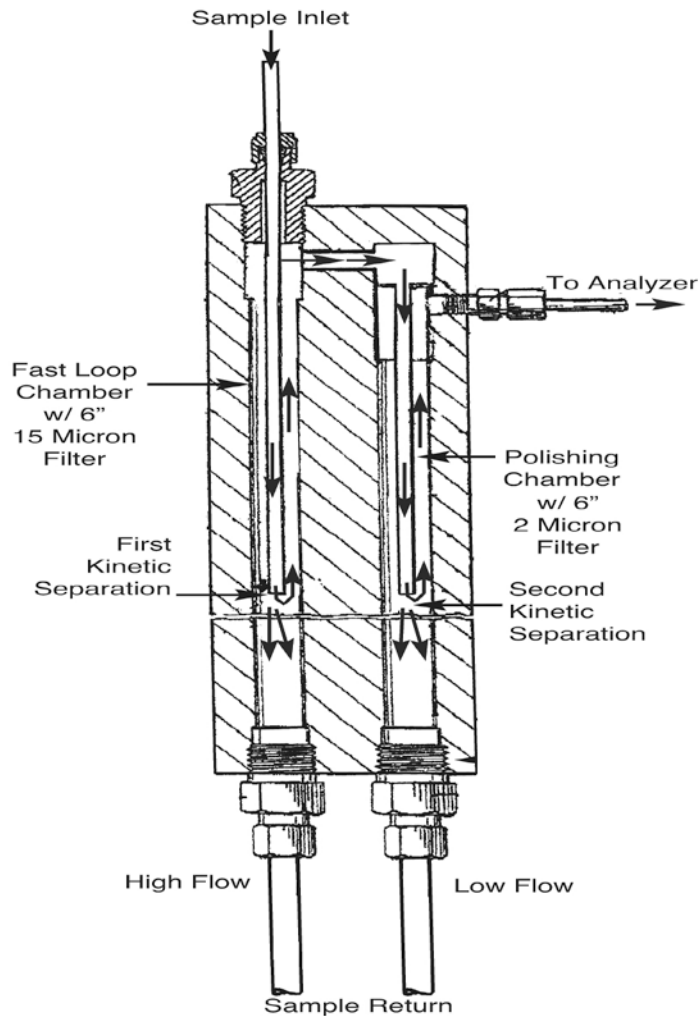

FIGURE 4. MEDIUM DUAL CHAMBER KINETIC SEPARATOR

BLOWBACK AND BACKFLUSH APPLICATIONS

Another area that seems uniquely fitted for dual chamber kinetic separation is the blowback and backflush applications. In either case a cylindrical woven wire stainless steel filter with varying pore size determined by the wire size and how densely it is wrapped. The filters have a passage in the middle which is larger than the outside diameter of the tube in that chamber. This allows for a common path between the filters. This path exits the bottom of the fast loop. The effluent from the outside of the stacked, common filters moves towards the low pressure return supplying the sealed chamber in the uppermost section of the second chamber which makes for a series configuration.

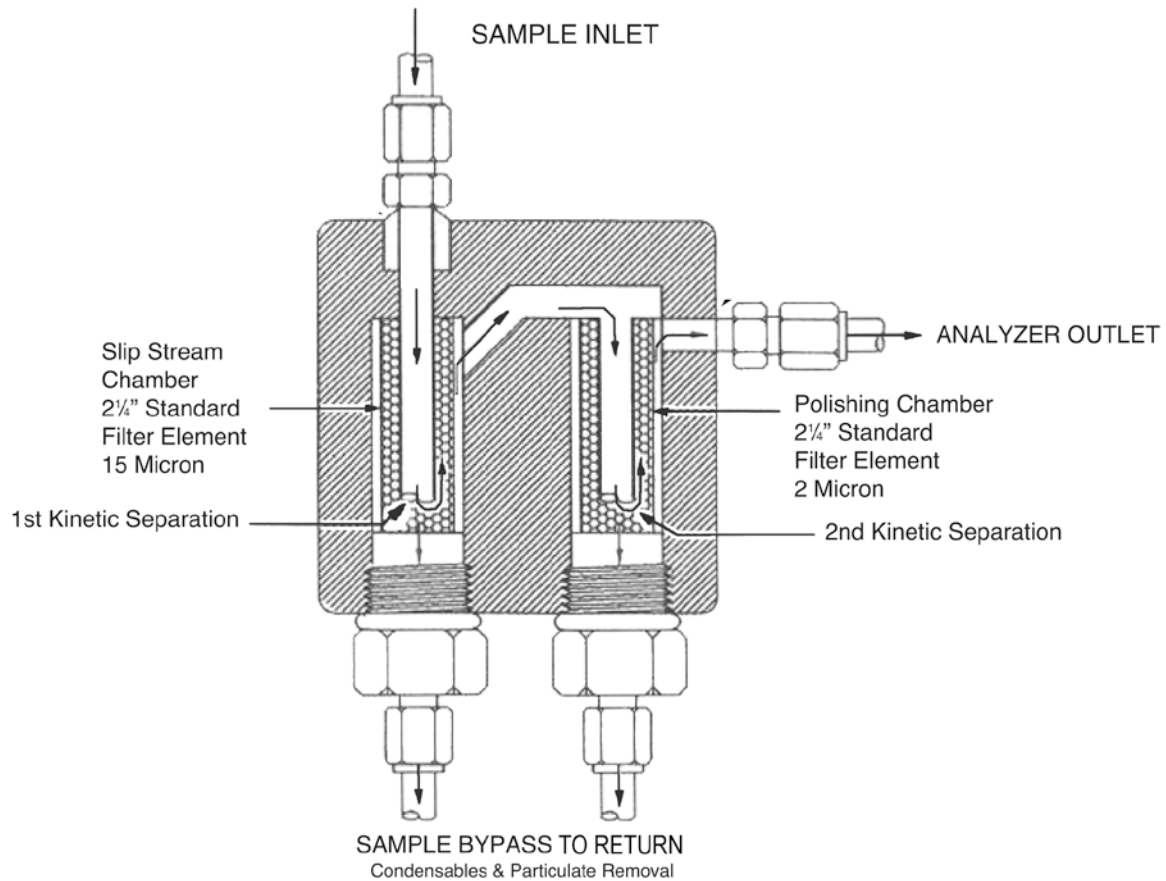

FIGURE 5-SMALL DUAL CHAMBER SEPARATOR

In the same manner as the first chamber the filters are stacked with a common internal path which exits to the return of the fast loop and the filtered sample flows to the analyzer port.. This continuous flow also keeps lag time to a minimum compared to the existing huge sock and large chamber filters used today. To accommodate the heavy particulate loading seen in these applications the first chamber is fitted with coarse filters and the second chamber, which is in series, has the specified porosity require for the analyzer. In cases where the pore size of the impurities is within a predictable narrow window the separator can be used in a parallel configuration with the same porosity filters in both chambers to accomplish twice the usable surface area.

This filter housing can be easily back flushed. With a simple back flush valve configuration sample, instrument air, potable water, or high pressure cylinder gas can be aligned to flush either chambers. The inside to outside path of the flow while in service is reversed and the outside to inside path routes the back flush stream through the filters and then exists the existing return. This can be accomplished with varying degrees of automation i.e., from manual valves to totally automated systems.

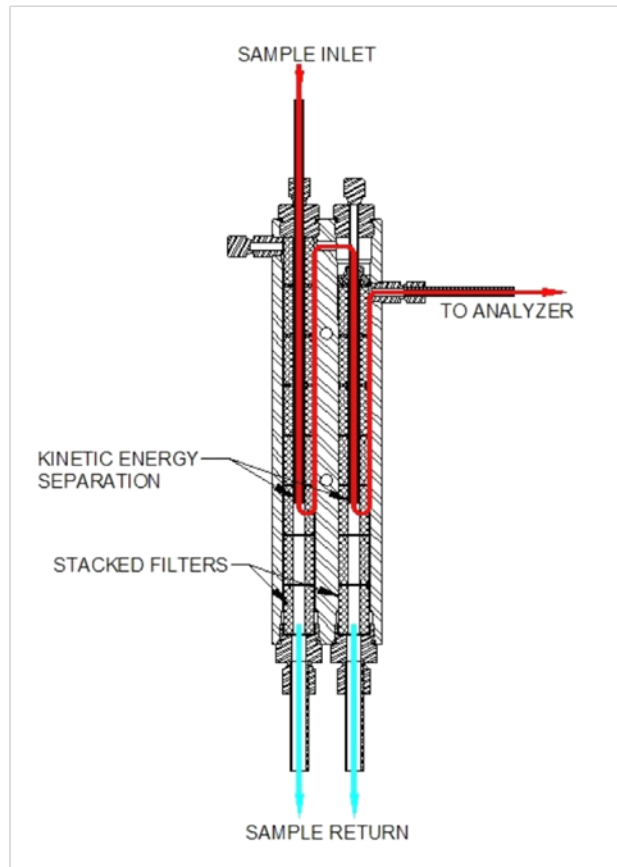

FIGURE 6. BACK FLUSH OR BLOW BACK DUAL CHAMBER KINETIC SEPARATOR.

This application can be used with fouled water, heavy oils, catalyst blow back, or when there is enough coarse contaminants in the sample system that prevents reasonable filter life. In the latter case, a woven filter appropriate for the specific coarse contaminant is used in the first chamber and a depth filter specified for the analyzer sample is used in the second chamber.

TEMPERATURE

The integrated cooler which has thinner chamber walls, adds versatility to the dual chamber kinetic separator. With less mass, the walls transfer heat and allow the body of the separator to be surrounded by the cooler. The coolant flows across the thinner walls absorbing the heat of the sample as it radiates through the chamber walls. This heat can be re-routed back to the exit tubing to the analyzer to maintain a temperature above the dew point. When used inside a heated cabinet the difference between that temperature and the temperature of instrument air is frequently sufficient to remove the condensables. “In practice, an actual cooler would be unnecessary as gases cool down instantly when they touch cold metal.” (3)

See Figure 7, below.

Other kinetic separators requiring only nominal sample temperature control may use a Vortex cooler to direct cool air to the separator body to achieve external cooling. The sample temperature can be controlled more precisely with a Peltier cooler in a more localized area of the second chamber.

PRESSURE DROP

Low differential pressure and low flow to the analyzer are the requisites for good coalescing of water across a filter in gas or liquid applications. It should be noted “sample velocity is critical in the operation of coalescing filters since Stokes Law will preclude phase separation if the sample velocity is too high and the phase density difference is too low.” (2) When utilizing separator technology, the differential pressure at any point in either chamber is less than 2 psi at any point because the fast loop exit flow, the polisher chamber exit flow, and the analyzer exit flow are controlled by small flow controllers such as rotameters, which maintain backpressure. Free water droplets are coalesced more efficiently, and particles are not as likely to adhere to the filter wall since high differential pressure is not forcing them through. This compliments the low flow typically specified for analyzers. The advantage to a kinetic separator is that they can use both edge and depth hydrophobic filters without the concern that a high differential pressure will force the water molecules through the filters as it does with membrane technology.

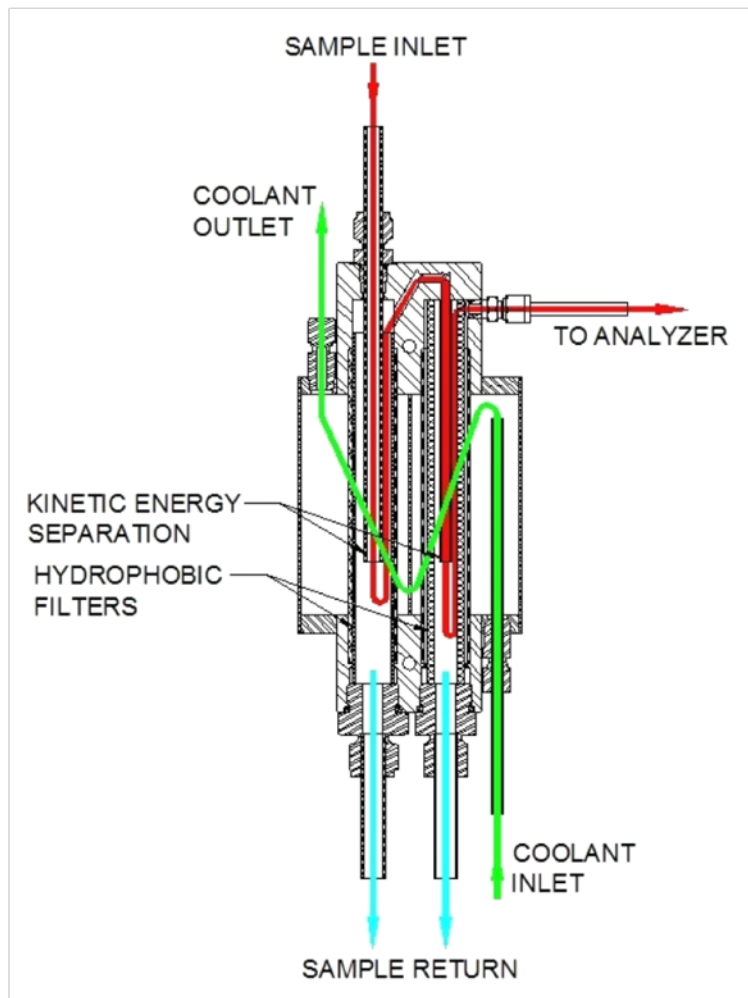

FIGURE 7. DUAL CHAMBER KINETIC SEPARATOR WITH COOLER

CONCLUSION

The basic criteria for a sample handling device is to deliver a representative sample which is compatible with the analyzer with an acceptable response time in a safe, reliable, and cost effective manner. (1) A representative sample may vary from the exact composition of a sample stream within predetermined and acceptable tolerances. Much of the same trade-off exists to meet compatibility demands “for ideally representative sampling, the sample would be presented to the analyzer in exactly the same condition as it exists in the process. Most analyzers however, require that the sample be modified in some way to make it compatible with the technique of measurement (e.g., cooling, pressure reduction, and condensate removal).” (1)

The underlying theme for representative and compatible samples is a pragmatic approach using only the tools necessary. This is easily accomplished with kinetic separation. A separator can be specified with only the options and size necessary to meet compatibility issues, which will preserve the sample in a state with predictable differences from the unconditioned stream. The components removed by kinetic separation are too heavy to be considered part of the analysis and will not be compatible with any but select analyzers such as those on a water stream.

The distance-velocity lag of the sample transport system is limited only by the physical constraints of the system. The straight through nature of the first chamber does not appreciably inhibit the flow. Kinetic separator lag time is minimized in both fast loop and single line applications. Both applications benefit from the lack of first order lag time consideration and the low volume of both chambers. The fast loop benefits from the significant flow exiting both chambers and the single line benefits from a reduced compressibility factor.

From a reliability perspective, the kinetic separator can be constructed of varying materials to meet compatibility requirements of the service. Since separators are most commonly constructed of stainless steel and Teflon without moving parts, the only maintenance required is filter replacement. These devices provide considerably more filtration without lag time issues which makes for a cleaner sample with longer filter life. As a practical matter, kinetic separators are successful in a very wide spectrum of pressure, temperature, and flow. The varying models can function in virtually any range of these components within the safe effective operating range of the body i.e., other than the obvious requirement to have enough flow and pressure to push contaminants to the sample return. Kinetic separators can do the worst case samples and rarely fail. It is a sealed system at ground level rated for high pressure service, and returns all contaminants to the process in a fast loop application.

Dual chamber kinetic separation is safe, simple, and cost effective, with relatively low initial cost and very low maintenance. Only one separator is necessary, with the options determined by the application. Options may also be added after installation. The separator can be used in high or low flow rates, with a high or low pressure, with temperatures to 150 Celsius and with liquid or gas applications.

“The process sample presented to the process analyzer should be of similar quality to the calibration material presented to the analyzer.”(4) Careful use of kinetic separation along with appropriate filters will result in a sample that is, as near as possible, of similar quality to the calibration material presented to the analyzer.

REFERENCES

- (1)Clevett, Kenneth J. Process Analyzer Technology, Ed.1, Vol. 1,
John Wiley and Sons, Inc., New York: 1986 952pages
- (2)Sherman, Robert E. Process Analyzer Sample Conditioning System Technology, Ed. 1, Vol.1,
John Wiley and Sons, Inc., New York: 2002 634pp
- (3)Waters, Tony Industrial Sampling Systems Reliable Design & Maintenance for Process Analyzers, Ed. 1, Vol.1,
Swagelok Company, 2013 744pp
- (4) Professional communication between this author and the author of Process Analyzer Sample Conditioning System Technology on 04 Feb. 2014